

# Modular Power Series

## 12 Volt DC 1RU Redundant Hot Swap Modular Power System

The ICT Modular Power Series system provides flexible, managed DC power for a broad range of RF communications and industrial DC power applications. The foundation is the power shelf and 700 watt high efficiency power module. A number of optional factory-installed modules can be selected to provide TCP/IP monitoring and control, advanced battery management features, battery breakers, low voltage disconnects, and four-position breaker-protected power distribution including load current monitoring and remote power cycling over Ethernet.



### Overview

The ICT Modular Power Series provides N+1 redundancy with 700 watt hot swappable 12 volt power modules. The power shelf can accommodate one to four power modules and one or two accessory modules. A dedicated slot holds the optional Intelligent Control Module for full TCP/IP remote monitoring and control. When combined with the optional Battery Management Module, the Intelligent Control Module also provides advanced battery functions including battery state of charge, estimated run time remaining, and battery discharge testing.

### Power Shelf

- ▶ Power Shelf with optional fully integrated Intelligent Control Module provides remote monitoring and control of DC power system over Ethernet
- ▶ Up to 2800 watts of power with redundancy in a single shelf
- ▶ Second shelf can be added for higher power applications
- ▶ Hot swappable 700 watt, high efficiency power modules
- ▶ Accommodates optional Battery Management Module and Load Distribution Module in 1RU space
- ▶ Flexible configurations allow you to select the right DC power system for your needs

### Power Modules

- ▶ 100-300 volts AC input with Power Factor Correction
- ▶ 120/240VAC input with no power de-rating
- ▶ 700 watt hot-swappable Power Modules
- ▶ 12 volts nominal DC output (floating ground)
- ▶ 90% efficiency
- ▶ -30 to +60C operating temperature range

### Load Distribution Module

- ▶ TCP/IP remote management and power control of individual outputs (with Intelligent Control Module installed)
- ▶ Four fully managed load outputs can be power cycled individually
- ▶ Monitoring and alarm reporting of each output for pinpointing of issues with connected loads
- ▶ Adjustable alarm and load-shed settings for each output

### Intelligent Control Module

- ▶ High resolution OLED display with Intelligent front panel controls fully integrated into Power Shelf
- ▶ TCP/IP remote Ethernet communications
- ▶ Embedded web server with easy to use Graphical User Interface
- ▶ Intelligent monitoring, reporting and control of system and all installed modules
- ▶ Full monitoring and control of second slave power shelf
- ▶ HTTPS, SMTP, SNMP protocols supported
- ▶ Alarms can be sent to multiple email accounts
- ▶ Four site monitoring sensor inputs with alarm reporting
- ▶ Data logging
- ▶ Password protection

### Battery Management Module

- ▶ Single or dual 100 amp battery disconnect circuit breakers
- ▶ Integrated 150 amp low voltage disconnect
- ▶ Advanced battery management features (with Intelligent Control Module installed) including temperature compensated charging, display of battery voltage, status, battery current, state of charge, run time remaining; adjust LVD settings; configure advanced battery management features such as boost charge parameters, max charge current, battery capacity, battery test timer, and battery discharge test cut-off voltage

## AC INPUT

Nominal input voltage	120/240VAC
Input voltage range	100-300VAC
Power factor (typical)	0.99
Frequency	50/60Hz

## DC OUTPUT 12 VDC

Power output per module	700W
Output current per Power Module	50A
Max. system output current with 4 Power Modules (120/240VAC)	150A (current limited)
Efficiency (typical)	90%
Output ripple (rms)	30mV
Output voltage range (adjustable)	11.5 - 15.5 VDC

## MECHANICAL

AC input connector	Terminal Block, #8 - #16 AWG
DC output connector	Busbars with 1/4-20 x 7/8" bolts
Remote alarm connectors	Terminal Block (#16 -24 AWG)
Mounting	1RU, 19 in rack mount
Weight (Power Shelf empty)	8.1lbs / 3.7 kg
Weight (Power Shelf + 4 modules)	18.5 lbs / 8.4 kg
Dimensions - H X W X L	1.74 x 19.0 x 15.7 in. / 44 x 483 x 398 mm

## ENVIRONMENTAL

Operating temperature range	-30° to +60° C
Output derating	2% /°C (above 50° C)
Storage temperature	-45° to +85° C

## DESIGN STANDARDS

Safety	EN 60950-1
Other	ROHS

## FACTORY INSTALLED OPTIONS <sup>(a)</sup>

### POWER SHELF WITH INTEGRATED INTELLIGENT CONTROL MODULE

Front display	High resolution OLED with function keys
Remote communications	TCP/IP - RJ45 Ethernet connector on rear
I.P. protocols	10/100 BASE-T, HTTPS, HTML, SNMP
Inputs	4 digital, 1 analog temp sensor contacts
Monitoring functions	See ICM data sheet
Control functions	See ICM data sheet

### POWER SHELF WITH LOAD DISTRIBUTION MODULE

Load outputs	4
System current rating	80A
Max. breaker size	30A <sup>(b)</sup>
Protection	Hydraulic/magnetic circuit breakers <sup>(c)</sup>
Remote current monitoring	Yes, with ICM installed
Remote power control of outputs	Yes, with ICM installed

### POWER SHELF WITH BATTERY MANAGEMENT MODULE

Circuit breaker	Single or Dual 100A <sup>(d)</sup>
Low voltage disconnect	150A contactor
Battery terminal	Busbar with 3/8" bolt

(a) Battery Management Module and Load Distribution Module require Power Shelf with integrated Intelligent Control Module (ICT-IPS).

(b) Load breakers must be ordered separately.

(c) Breakers and wiring should be continuously operated at no more than 80% of their current rating.

(d) Must be specified at time of ordering. Battery disconnect breakers are installed at factory. For high current load breaker configuration contact ICT.

**STEP 1 Select Power Shelf**

Select the Power Shelf that meets your requirement for DC voltage, ground, battery management, and load distribution features.

Description	Model Number
Intelligent Power Shelf with integrated Control Module and Ethernet communications. 1400 Watts Maximum. Factory-installed 100A Battery Management Module with Low Voltage Disconnect and four position Intelligent Load Distribution Module.	POS 12VDC (neg ground) ICT-IPS-BMM-LDMP
Intelligent Power Shelf with integrated Control Module and Ethernet communications. 1400 Watts Maximum. Factory-installed dual 100A Battery Breakers with Low Voltage Disconnect and four position Intelligent Load Distribution Module.	ICT-IPS-BMMD-LDMP
Intelligent Power Shelf with integrated Control Module and Ethernet communications. 1400 watts Maximum. Factory-installed intelligent load distribution modules provide eight positions.	ICT-IPS-LDM-LDMP
Intelligent Power Shelf with integrated Control Module and Ethernet communications. 2100 Watts Maximum. Factory-installed 100A Battery Management Module with Low Voltage Disconnect.	ICT-IPS-BMMP
Intelligent Power Shelf with integrated Control Module and Ethernet communications. 2100 Watts Maximum. Factory-installed dual 100A Battery Breakers with Low Voltage Disconnect.	ICT-IPS-BMMDP
Intelligent Power Shelf with integrated Control Module and Ethernet Communications. 2100 Watts Maximum. Factory-installed four position Intelligent Load Distribution Module.	ICT-IPS-LDMP
Intelligent Power Shelf with integrated Control Module and Ethernet Communications. 2800 Watts Maximum. Accepts up to four Power Modules.	ICT-IPS
Standard Power Shelf accepts up to four Power Modules. Designed to combine with ICT-IPS Intelligent Power Shelf, ICT-JMP and ICT-PAR to provide expanded power system with up to 4900 Watts of Ethernet-managed power.	ICT-SPS

Note: NEG 12VDC (pos ground) available. Contact factory.

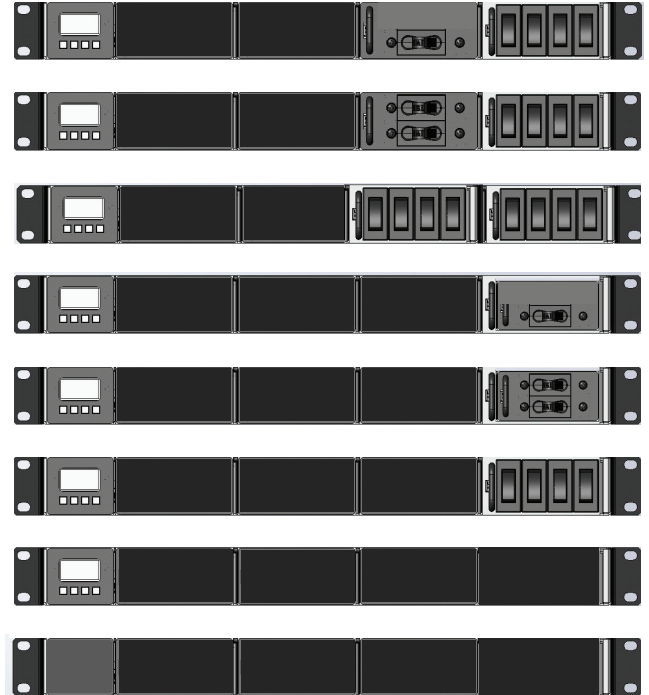

**STEP 2 Select Power Modules**

Depending on the Power Shelf selected, up to four hot-swappable Power Modules can be installed (must be same voltage).

Description	Model Number
Power Module, 12VDC, 700W output, hot swappable, floating output	ICT700-12PM
Optional blanking panel for unused Power Module positions	ICT-BPM



**Descriptions**

**INTELLIGENT POWER SHELF**

Includes fully integrated Ethernet controller to provide remote monitoring and control of system and installed options. HTTPS, SMTP and SNMP supported. Four site monitoring input contacts. Provides advanced battery management features when used with Battery Management Module including temperature compensated charging, battery state-of-charge, run-time remaining, battery discharge testing.

**BATTERY MANAGEMENT MODULE**

Factory installed option. Includes 150A Low Voltage Disconnect and single or dual string 100A Battery disconnect Circuit Breakers. (Contact factory to configure one 100A Load Disconnect Breaker.) Monitor and adjust LVD setpoints over Ethernet. Battery disconnect breaker will send alarm via Ethernet and Form C contacts.

**LOAD DISTRIBUTION MODULE**







Factory installed option. Provides four breaker-protected load outputs. Monitor and power cycle each load individually via Ethernet. Sends email alarms. Automatic load shedding and network watchdog (ping) features maximize run-time for critical loads and will power cycle critical devices such as routers, possibly preventing unplanned trips to the site.

**CUSTOM CONFIGURATIONS**

Contact factory to discuss custom configuration requirements.

**STEP 3 Select Load Breakers and Accessories**

If you selected a Power Shelf with Load Distribution Module installed, select up to four Hydraulic/Magnetic load breakers.

Description	Model Number	Description	Model Number
5 Amp Hydraulic/Magnetic breaker for use with Load Distribution Module	ICT-CB5 	Allows Smart Parallel Operation with automatic load sharing when paralleling ICT-SPS with ICT-IPS.	ICT-JMP 
10 Amp Hydraulic/Magnetic breaker for use with Load Distribution Module	ICT-CB10 	Allows paralleling of output bus bars when installing ICT-SPS as a slave power shelf to ICT-IPS.	ICT-PAR 
15 Amp Hydraulic/Magnetic breaker for use with Load Distribution Module	ICT-CB15 		
25 Amp Hydraulic/Magnetic breaker for use with Load Distribution Module	ICT-CB25 		
30 Amp Hydraulic/Magnetic breaker for use with Load Distribution Module	ICT-CB30 